



Research Paper

# DESIGN AND ANALYSIS OF JET WIND TURBINE BLADES

Vishal N Sulakhe<sup>1\*</sup> and Satish G Bahale<sup>2</sup>

\*Corresponding Author: **Vishal N Sulakhe**, ✉ [vishal.sulakhe1989@gmail.com](mailto:vishal.sulakhe1989@gmail.com)

This paper summarizes the design and analysis of Jet Wind Turbine blades, CATIA is used for design and analysis for model generated by applying boundary condition; this paper also includes specific post processing and life assessment of blade. We take an opportunity to present this report on “Design and Analysis of Jet Wind Turbine Blades” and put before readers some useful information regarding this project. Drawn by list of priorities progress in the design and structural analysis of jet wind turbine blades is reviewed and presented for generating 100 watt power. This article is motivated by the key role of blades in the performance of jet wind turbine. The fundamentals of the associated physics are emphasized. Recent developments and advancements have led to an increase and improvement in blade aerodynamics, stability and reliability. This article is intended as a high level review of design of the blade environment and current state of structural design to aid further research in developing new and innovative blade technologies.

**Keywords:** Design and analysis, Wind turbine, CATIA

## INTRODUCTION

### Wind as an Energy Resource

One of the earliest non-animal sources of power used by man was the wind turbine. Wind turbines have been in documented use for more than 1,000 years. The earliest wind turbine designs were extremely simple; turbines were allowed to rotate at a rate proportional to the velocity of the wind. They

were used to pump water, grind grain, cut lumber, and perform a myriad of other tasks. For these purposes, varying speed seldom impacted the effectiveness of the windmill enough to justify the complications of closely controlling rotational speed. Allowing the machines to run at variable speed was in fact highly advantageous as it greatly increased the total energy that could be extracted from the wind.

<sup>1</sup> Department of Mechanical Engineering, Rajarshi Shahu College of Engineering Malvihir, Sagwan Road Buldana Dist., Buldana 443001, MH.

<sup>2</sup> Department of Mechanical Engineering, Prof. Ram Meghe Institute of Technology and Management, Badnera, Amravati Dist., Amravati 444601, India.

However, in rural India, where the word “electricity” is still a dream, millions of people do not have access to electricity in their homes. In fact, four out of these five people without electricity live in far flung villages and isolated countryside hamlets, some of which are geographically isolated and are often too sparsely populated or have a too low potential electricity demand to justify the extension of the grid. Thus, to provide access to electricity in these rural areas through other means than the extension of the grid, renewable energy like wind power is among the least cost and most feasible solution (Nagendra, 2009).

The earliest horizontal-axis windmill to use the principles of aerodynamic lift instead of drag may have been introduced in the twelfth century. These horizontal-axis sail turbines were allowed to run at varying speeds, limited only by braking or furling to control their speed during storms. These designs operated throughout Europe and in the Americas into the present century. In the 700 or so years since the first sail- wing turbine, designers discovered many of the key principles of aerodynamics without understanding the physics behind them. It was not until the nineteenth century that these principles began to be clearly understood (Carlin *et al.*, 2001).

The cost of wind-generated electric power has dropped substantially. Since 2004, according to some sources, the price in the United States is now lower than the cost of fuel-generated electric power, even without taking externalities into account. In 2005, wind energy cost one-fifth as much as it did in the late 1990s, and that downward trend is expected to continue as larger multi-megawatt turbines are mass-produced. Wind power is growing

quickly, at about 38%, up from 25% growth in 2002. Wind power is the fastest growing form of electricity generation on a percentage basis.

### **Jet wind Turbine Blades**

Jet turbine surrounds its wind-turbine blades with a shroud that directs air through the blades and speeds it up, which increases power production. The new design generates as much power as a conventional wind turbine with blades twice as big in diameter. The smaller blade size and other factors allow the new turbines to be packed closer together than conventional turbines, increasing the amount of power that can be generated per acre of land. The idea of enshrouding wind-turbine blades isn't new. But earlier designs were too big to be practical, or they didn't perform well, in part because the blades had to be very closely aligned to the direction of the wind—within three or four degrees (Douglas *et al.*, 2011).

This turbine design surrounds its wind-turbine blades with a shroud that directs air through the blades and speeds it up, which increases power production. The shroud concept is based on the same principles as a high bypass jet engine design that is used by all commercial jet aircraft engines to reduce noise and significantly improve efficiency. The new design generates as much power as a conventional wind turbine with blades twice as big in diameter. The smaller blade size and other factors allow the new turbines to be packed closer together in the field compared to conventional turbines, increasing the amount of power that can be generated per acre of land. As air approaches, it first encounters a set of fixed blades, called the stator which are common in jet and steam

turbines designs used in power generation, which redirect the air onto a set of movable blades, called the rotor. The air turns the rotor and emerges on the other side, moving more slowly now than the air flowing outside the turbine. The shroud is shaped so that it guides this relatively fast-moving outside air into the area just behind the rotors. The fast-moving air speeds up the slow-moving air, creating an area of low pressure behind the turbine blades that sucks more air through them. We are designing Jet wind turbine blades for generating 100 watt power and to be made simple and small, giving it the ability to handle high wind velocities due to its effectiveness to handle off axis flow and turbulence (William, 2010).

### Design and Calculation

We are designing Jet Wind Turbine blades for 100 Watt electricity production.

### Annual Energy Requirement for a Single Home

The energy consumed by a single home in rural area is,

Consider,

2 bulb of 20 watt per hour (CFL)

$$= 2 \times 20 = 40 \text{ watt}$$

1 Fan of 40 watt per hour

$$= 1 \times 40 = 40 \text{ watt}$$

1 TV set 10 watt per hour

$$= 1 \times 10 = 10 \text{ watt}$$

1 Freeze of 10 watt per hour

$$= 1 \times 10 = 10 \text{ watt}$$

So, total energy consumption is 100 watt per hour approximately.

Total annual energy consumption

$$= \text{Energy consumption per hour} \times \text{total annual hour's}$$

$$= 100 \times 8760$$

$$= 876000 \text{ Wh}$$

But this is the energy when wind will flow at rated wind speed throughout the year, which is never a case.

Therefore in order to get realistic energy output, we have to multiply the above numbers by the Capacity Factor (CF). For wind energy capacity factor is assumed to be 30%.

Annual Energy Production

$$= \text{Energy consumption/ hour} \times \text{total annual hour's} \times \text{CF}$$

$$= 100 \times 8760 \times 0.3$$

$$= 262800 \text{ Wh}$$

### Calculation of Power Density of Wind (Power per Unit Area)

Ideal Power density of air (15 meter height is considered)

$$= \frac{1}{2} \times \text{air density} \times (\text{velocity})^3$$

$$= 0.5 \times 1 \times (5 \times 5 \times 5)^3$$

$$= 62.5 \text{ Watt/m}^2$$

Actual power density that will be converted to useful energy

$$= \text{Power density} \times [C_p \times \text{transmission losses} \times \text{generator losses}]$$

Considering losses,

- Coefficient of performance = 0.40
- Transmission losses (rotor to generator) = 0.90
- Generator losses = 0.90

Overall loss factor =  $C_p \times$  transmission losses  $\times$  generator losses

$$= 0.40 \times 0.90 \times 0.90$$

$$= 0.324$$

Actual power density =  $62.5 \times 0.324$

$$= 20.25 \text{ W/m}^2$$

Annual energy density (useful)

= Power density  $\times$  no of hours per Year

$$= 20.25 \times 8760$$

$$= 177390 \text{ Wh/m}^2$$

By considering the capacity factor (30%)

Real annual energy density

= Annual energy density (useful)  $\times$  capacity factor

$$= 177390 \times 0.30$$

$$= 53200 \text{ Wh/m}^2$$

### Calculation of Rotor (Blade) Size

Area of the rotor = Total annual energy required/Real annual energy density

$$= 262800/53200$$

$$= 4.94 \text{ m}^2$$

Radius of the rotor blade ( $R$ ),

$$\pi R^2 = 4.94$$

$$R = 1.25 \text{ m}$$

### Power Rating of Windmill

= Actual power density  $\times$  area of rotor

=  $\frac{1}{2} \times$  air density  $\times$  (velocity)<sup>3</sup>  $\times$  area of rotor

$$= 20.25 \times 4.94$$

$$= 100 \text{ watt}$$

### Tip Speed Ratio

$$TSR = \omega R/V$$

where,

$\omega$  – Angular speed in radians

$R$  – Rotor blade radius in meter

$V$  – Wind Speed in m/s

$$TSR = (2\pi N/60 * 1.25)/5$$

$$= (2\pi * R)/5$$

$$= (2\pi \times 1.25)/5$$

$$= 7.85/5$$

$$TSR = 1.6$$

$$= 2$$

So, number of blades would be 08 to 12.

**Design of Rotor Blade:** Design of rotor blade of Prototype

Chord Length ' $C$ ' = 0.25 m

Span of airfoil  $L$  = 1.25 m

Velocity of the airfoil ' $U$ ' = 60 rpm  $\times R$

$$= 60 \times 1.25$$

$$= 75 \text{ m/s}$$

**Figure 1: Angle of Attack vs. CL and CD**

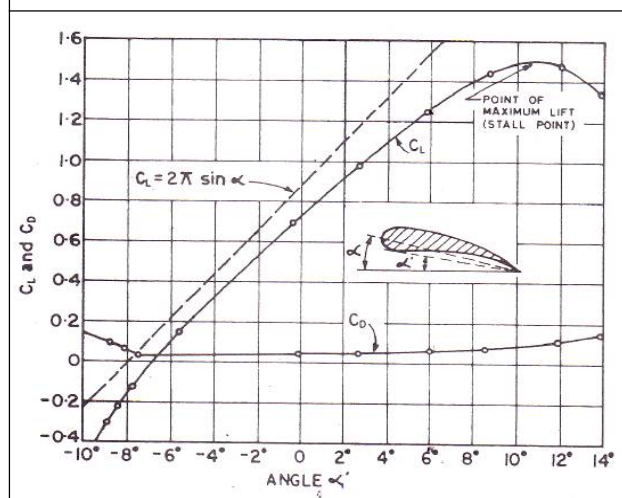

where,

Density of air = 1 kg/m<sup>3</sup>

Angle of attack 'α' = 60

From the above graph we find out the value of coefficient of drag and coefficient of lift.

Coefficient of Drag (C<sub>D</sub>) = 0.1

Coefficient of Lift (C<sub>L</sub>) = 1.3

**Lift Force**

$$F_L = C_L \times \rho \times A \times U^2/2$$

$$F_L = C_L \times \rho \times (C * L) \times U^2/2$$

$$F_L = 1.3 \times 1 \times (0.25 * 1.25) \times 75^2/2$$

$$F_L = 1142.57 \text{ N}$$

**Drag Force**

$$F_D = C_D \times \rho \times A \times U^2/2$$

$$F_D = C_D \times \rho \times (C * L) \times U^2/2$$

$$F_D = 0.1 \times 1 \times (0.25 * 1.25) \times 75^2/2$$

$$F_D = 87.89 \text{ N}$$

**Design of Shaft**

Torque transmitted by the shaft = F<sub>L</sub> × Length of the blade

$$= 1142.57 \times 1.25$$

$$= 1428.21 \text{ Nm}$$

Torque transmitted by the shaft = π/16 × τ × d<sup>3</sup>

where,

τ – Shear stress of Mild steel is 42 MPa = 42 N/mm<sup>2</sup>

d – Diameter of the shaft in mm

$$1428.21 \times 10^3 = \pi/16 \times 42 \times d^3$$

$$d^3 = 1428.21 / (0.19634 * 42)$$

$$d = 55.74 \text{ mm}$$

**MATERIAL SELECTION**

The proper selection of material for the different part of a machine is the main objective in the fabrication of machine. For a design engineer it is must that he be familiar with the effect, which the manufacturing process and heat treatment have on the properties of materials. The Choice of material for engineering purposes depends upon the following factors:

- Availability of the materials.
- Suitability of materials for the working condition in service.
- The cost of materials.
- Physical and chemical properties of material.
- Mechanical properties of material.

With this background, for small wind turbine it is better to use wood as a blade material (Tom, 1996).

**Drawing of Blades in CATIA**

With the help of above calculation for blades we draw blade in CATIA. Some snapshot of these blades is shown in following Figures 2 and 3:

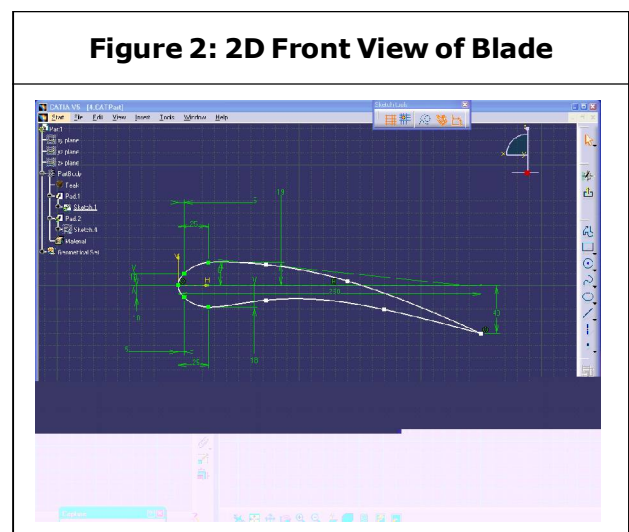

**Figure 3: 3D View of Blade**

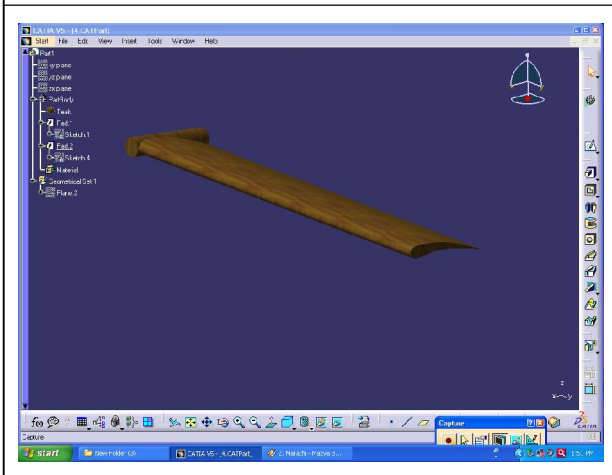

**Figure 5: Static Case Solution 1 – Deformed Mesh**



## RESULT OF ANALYSIS

The aim of structural analysis is to evaluate the external reactions, the deformed shape and internal stresses in the structure. If this can be accomplished by equations of equilibrium, then such structures are known as determinate structures. However, in many structures it is not possible to determine either reactions or internal stresses or both using equilibrium equations alone. Such structures are known as the statically indeterminate structures. The indeterminacy in a structure may be external, internal or both. A structure is said to be

**Figure 6: Static Case Solution 1 – Von Mises Stress (Nodal Values)**

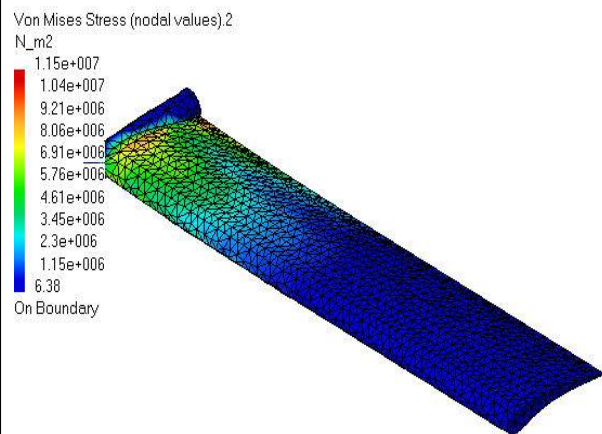

**Figure 4: Boundary Conditions**

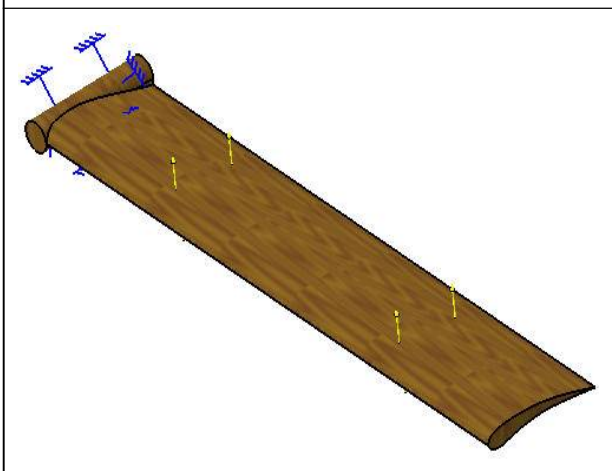

**Figure 7: Static Case Solution 1 – Deformed Mesh**

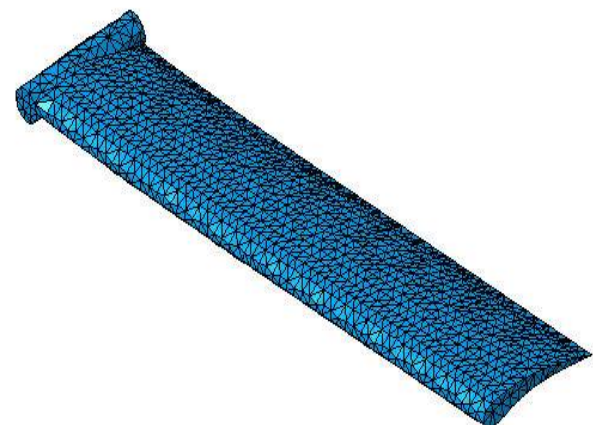



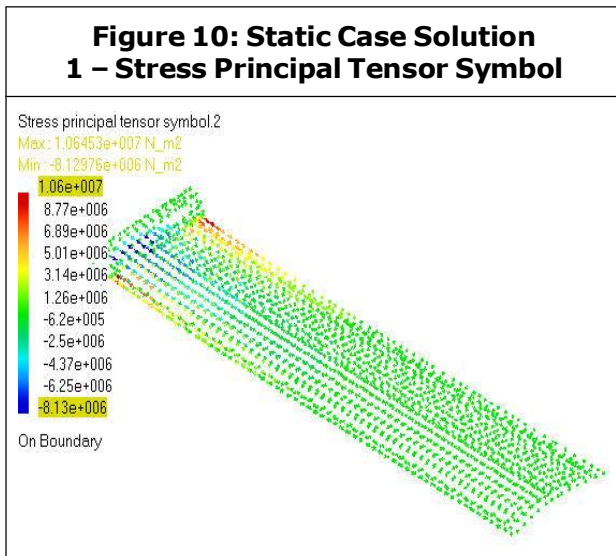
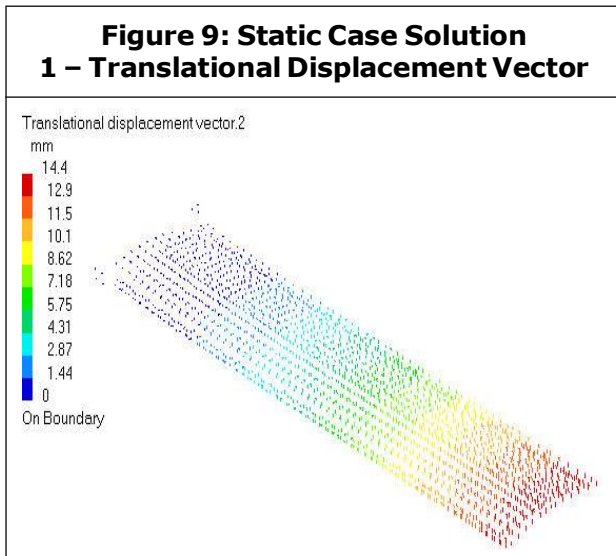
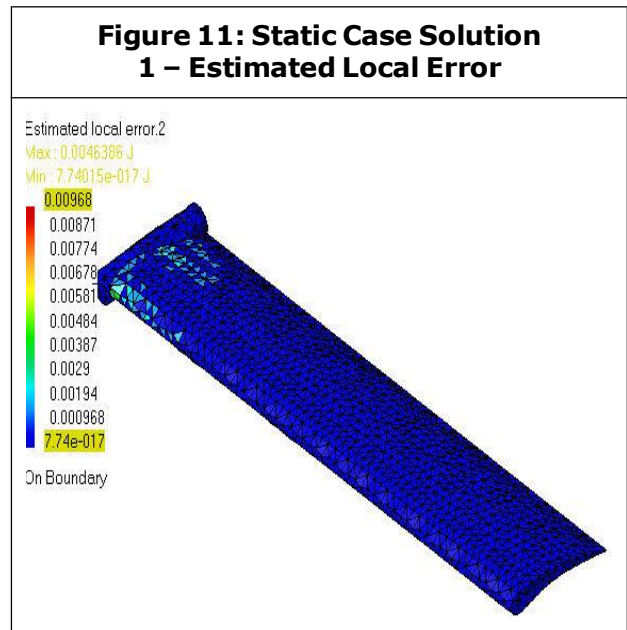
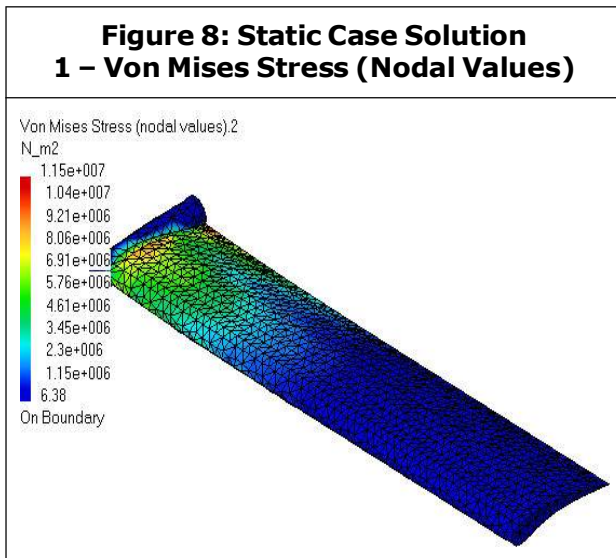

externally indeterminate if the number of reactions exceeds the number of equilibrium equations (Rossiter, 2006).

## RESULTS AND DISCUSSION

In the Jet Wind Turbine when air is approached to stator, it acts as a nozzle that the velocity of wind increases and pressure decreases. Due to this, velocity of airfoil increases rotor spins and produce much power and decreasing pressure results in suction of wind. While comparing JWT with conventional wind turbine due to stator, velocity of the air is increase from 3 m/s to 5 m/s. Average wind velocity is 3 m/s in Chikhli Buldana (M.H) observed by reading.

The velocity is directly proportional to the power, so velocity of wind increases results, and increase in power.

Average wind speed

$$= (2.96 + 2.53 + 3.36 + 3.3 + 2.7)/5$$

$$= 2.97 \text{ m/s}$$

<b>Table 1: Readings</b>				
Date	Time			Average Wind Velocity in m/s
	11.00 am	2.00 pm	4.00 pm	
	Wind Velocity in m/s			
14 February	2.8	3.8	2.3	2.96
15 February	2.9	2.3	2.4	2.53
16 February	3.6	2.3	4.2	3.36
18 February	3.4	2.7	3.8	3.3
20 February	3	2.5	2.6	2.7

**Power Rating of Conventional Windmill for 100 Watt**

100 watt = Actual power density × area of rotor × overall losses

$$= \frac{1}{2} \times \text{air density} \times (\text{velocity})^3 \times \text{area of rotor} \times \text{Overall losses}$$

$$= 0.5 * 1 * 3^3 * 0.324 * \text{Area of rotor}$$

$$\text{Area of rotor} = 100 / 0.5 * 1 * 3^3 * 0.324$$

$$= 22.86 \text{ m}^2$$

Radius of the rotor blade (R),

$$\text{Area of rotor} = \pi R^2$$

$$\pi R^2 = 22.98 \text{ m}^2$$

$$R = 2.70 \text{ m}$$

Aspect ratio L/C is 5 so chord length becomes 0.54 m while comparing the Radius

length and chord length of the conventional blade with jet wind turbine blade.

It is observed that Radius of the rotor and chord length of the conventional blade is 2.16 times greater than jet wind turbine blade. So material, floor space area is reduces and due to all above mentioned parameters efficiency increases due to JWT Blade. Structural design of JWT blades is as important as their aerodynamic design. The dynamic structural loads which a rotor will experience play the major role in determining the lifetime of the rotor. Obviously, aerodynamic loads are a major source of loading and must be well understood before the structural response can be accurately determined and also the blade geometry parameters are required for dynamic load analysis of wind turbine rotors.

<b>Table 2: Blade Geometry Output for Conventional and Designed Blade</b>				
Rotor Power in Watt	Rotor Radius (R) in Meter		Chord Length (C) in Meter	
	Conventional	Designed	Conventional	Designed
100	2.70	1.25	0.54	0.25
500	6.03	2.80	1.21	0.56
1000	8.53	3.97	1.71	0.79
1500	10.45	4.86	2.09	0.97
2000	12.07	5.61	2.41	1.12
2500	13.49	6.27	2.70	1.25



So such a study on the dynamic load analysis of JWT blades might also use the outputs of design theory.

## CONCLUSION

As the electricity is need of world also it is very important thing of our day to day life and wind is the cost-free source of energy. The concept of Jet Wind Turbine is more efficient than the conventional wind turbine and produces 3 to 4 times more power. The efficiency of Jet Wind Turbine is increases due to its aerodynamic blades shape along with stator that guides wind to increases the velocity and decrease the pressure to generate power. This JWT blade design process is simple and adequate to reduce the material and utilizes less space area as compare to conventional wind turbine.

We suggested that this blade design theory is very useful to produce power at minimum cost and more effectively. 🌀

## REFERENCES

1. Carlin P W, Laxson A S and Muljadi E B (2001), "The History and State of the Art of Variable-Speed Wind Turbine Technology", February, Presented at the National Renewable Energy Laboratory, Colorado.
2. Douglas S Cairns, Trey Riddle and Jared Nelson (2011), "Wind Turbine Composite Blade Manufacturing", February, Presented at the Sandia National Laboratories.
3. Grant Ingram (2011), "Wind Turbine Blade Analysis Using the Blade Element Momentum Method", Version 1.1, October 18.
4. Modi P N and Seth S M (2002), "Hydraulics & Fluid Mechanics", *Standard Book House*, pp. 824-831.
5. Nagendra Gopal K V (2009), "The Bulletin of The Energy Forum", March 4, Presented at the Energy Forum of IIT Madras, Department of Aerospace Engineering.
6. Rossiter D G (2006), "An Introduction to Statistical Analysis", January 9, Department of Earth Systems Analysis.
7. Tom Ritchey (1996), "Materials and Properties", *Systems Research*, Vol. 8, No. 4, pp. 21-41.
8. William J Bierbower (2010), "Breakthrough High Efficiency Shrouded Wind Turbine", Advanced Research Projects Agency – Energy, January 14, US Department of Energy.